

A46JE/A46JRT

ARTICULATED BOOM LIFTS



- Class-leading articulated boom lifts
- Choose from electric or rough terrain diesel models
- Highly manoeuvrable with tight turning radius
- Superb working envelope with zero tailswing
- Robust, reliable and easy to operate



snorkel[™]
www.snorkellifts.com

ARTICULATED BOOM LIFTS

A46JE/A46JRT

DIMENSIONS	A46JE	A46JRT
Max. working height	16.0m	16.3m
Max. platform height	14.0m	14.3m
Max. working outreach	7.35m	7.35m
Clearance height at max. outreach	7.46m	7.67m
Platform size	1.0m x 1.83m	1.0m x 1.83m
Chassis width (A)	1.7m	2.1m
Overall length (B)	5.6m	5.7m
Stowed height (C)	2.0m	2.16m
Ground clearance	152mm	330mm

PERFORMANCE		
Platform capacity (SWL)	227kg	227kg
Max. drive height	14.0m	14.3m
Max. wind speed	12.5m/s	12.5m/s
Max. drive speed (stowed)	5.1km/h	6.4km/h
Max. drive speed (elevated)	0.8km/h	1.3km/h
Jib length	1.5m	1.5m
Jib arc	140°	140°
Platform rotation	160°	160°
Turret rotation (non-continuous)	360°	360°
Tailswing	0m	0m
Raise/lower time	99/92 sec	101/98 sec
Gradeability	30%	45%
Inside turning radius	0.6m	0.8m
Outside turning radius	3.0m	3.17m
Tires	Non-marking IN240/55D 17.5	High grip, foam-filled 355/55D625NHS 17.5
Controls	proportional	proportional
Drive system	2-wheel drive	4-wheel drive

POWER		
Power source	8 x 6V 360Ah batteries	Kubota V1505 24.9hp Diesel
Battery charger	100-240V/10A	n/a

WEIGHT		
Weight	6,664kg	7,540 kg

WORKING ENVELOPE

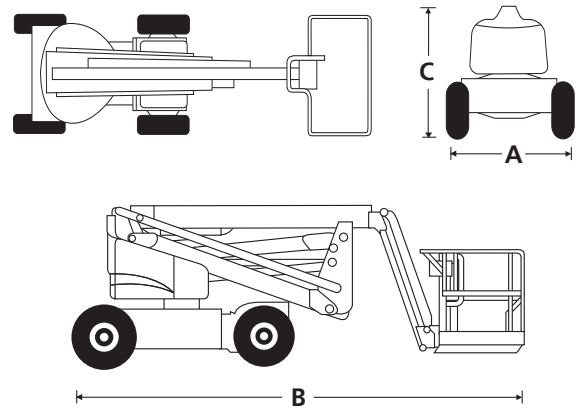
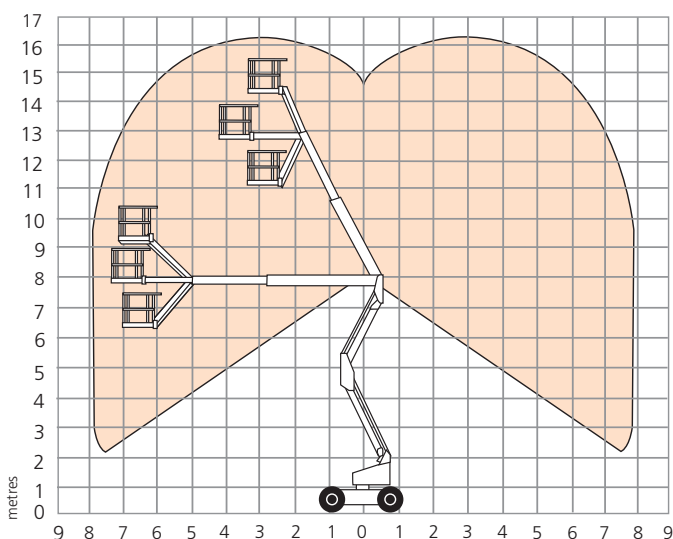

STANDARD FEATURES

- Snorkel Guard™ secondary guarding system
- Multi-function proportional controls
- Oscillating front axle (A46JRT)
- Tri-entry platform
- Power line to platform
- Zero tailswing
- Hour meter & on-board diagnostics display
- Tilt alarm
- Horn
- Drive motion alarm
- Flashing amber light
- Platform overload system
- Foam filled tires (A46JRT)
- Non-marking tires (A46JE)
- Battery charge indicator (A46JE)
- 2 year parts & labor, 5 year structural warranty
- ANSI compliant

OPTIONS

- Special paint colors
- AC generator 110V/2.5kW (A46JRT)
- Airline to platform
- Non-marking tires (A46JRT)
- Environmental hydraulic oil
- 1.52m aluminum platform with swing gate
- Aircraft package
- Deluxe aircraft package
- Cold weather package
- Extreme cold weather package (A46JRT)
- Extreme environment package
- Light package (A46JRT)
- Glazier package (A46JRT)
- Tool tray (A46JRT)
- Pipe rack
- Utility package (A46JRT)
- Personal fall arrest system (A46JRT)
- Snorkel OnSite™ telematics

snorkel

www.snorkellifts.com

P.O. Box 1160
St. Joseph, MO 64502-1160, USA
Tel: 1 (785) 989-3000
Toll-free: 1 (800) 255-0317
Fax: 1 (785) 989-3070

Email: sales.usa@snorkellifts.com